

Duckfoot bend N PN 10 and ductile iron PN 10/16

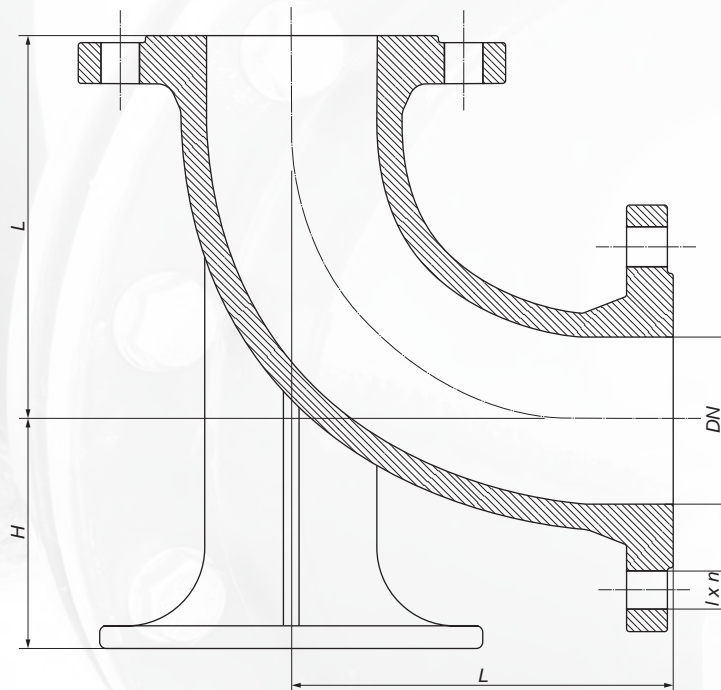

It is used to build supply systems
and extend the pipeline to the surface
(installation of hydrants).

Coating: bitumen paint,
poliester paint min. 250 μm
Material: cast iron EN-GJL-250, PN-EN 1561:2012
Flange connection: PN-EN 1092-2:1999
Nominal pressure: 1,0 MPa; PN 10

DN	L	H	l	n	Weight
80	165	110	18	4(8)	15,40
100	180	125	18	8	20,50
150	220	160	22	8	42,00

Coating: poliester paint min. 250 μm
Material: ductile iron, EN-GJS-500-7, PN-EN 1563:2018
Flange connection: PN-EN 1092-2:1999
Nominal pressure: 1,0/1,6 MPa; PN 10/16

DN	L	H	l	n	Weight
80	165	110	18	8	15,00
100	180	125	18	8	19,50
150	220	160	22	8	35,00
200	260	190	22	8(12)	51,00