

Telescope 160 with cover and grate

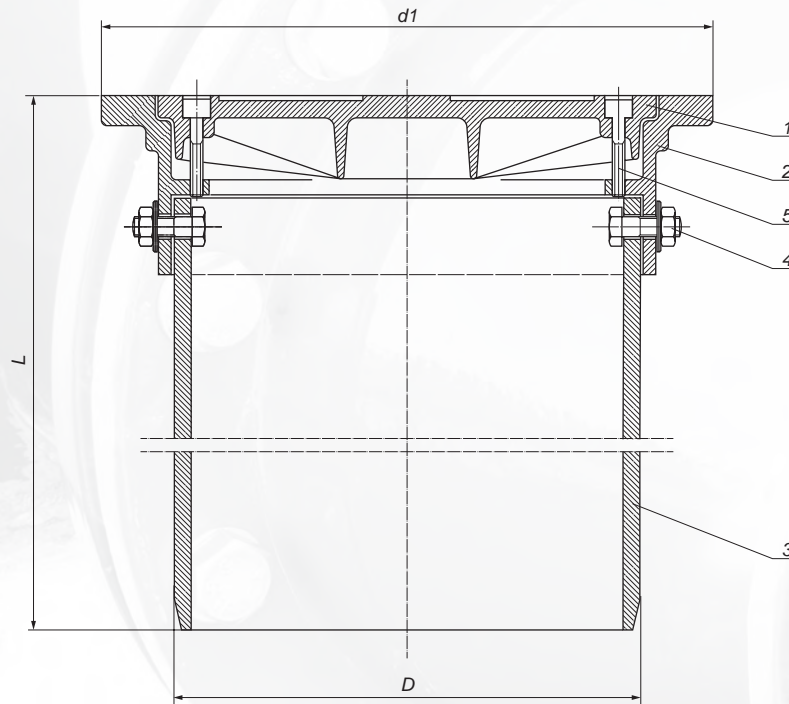

No.	Description	Material
1.	Lid	EN-GJL-250
2.	Body	EN-GJL-250
3.	Pipe	PVC 160
4.	Screw, pad, nut	Galvanized steel 8.8 class/ Stainless steel A2
5.	Allen screw	Galvanized steel 8.8 class/ Stainless steel A2

No. 1., 2. bitumen paint.
Material: cast iron EN-GJL-250, PN-EN 1561:2012

It is used as a top of inspection chamber size 160/200.
Based on a smooth pipe Dn 160 and connected to the rising
smooth pipe Dn 200 by the MW 160/200 rubber adaptor.

Lid type	Load	Class	D	L	d1	Weight
Cover	1,5 T	A 15	160	500	250	8,00
	40 T	D 400	160	500	250	19,00
Grate	1,5 T	A 15	160	500	250	7,80

Norm: PN-EN 124-2