

Flanged adaptor RK ductile iron PN 10/16

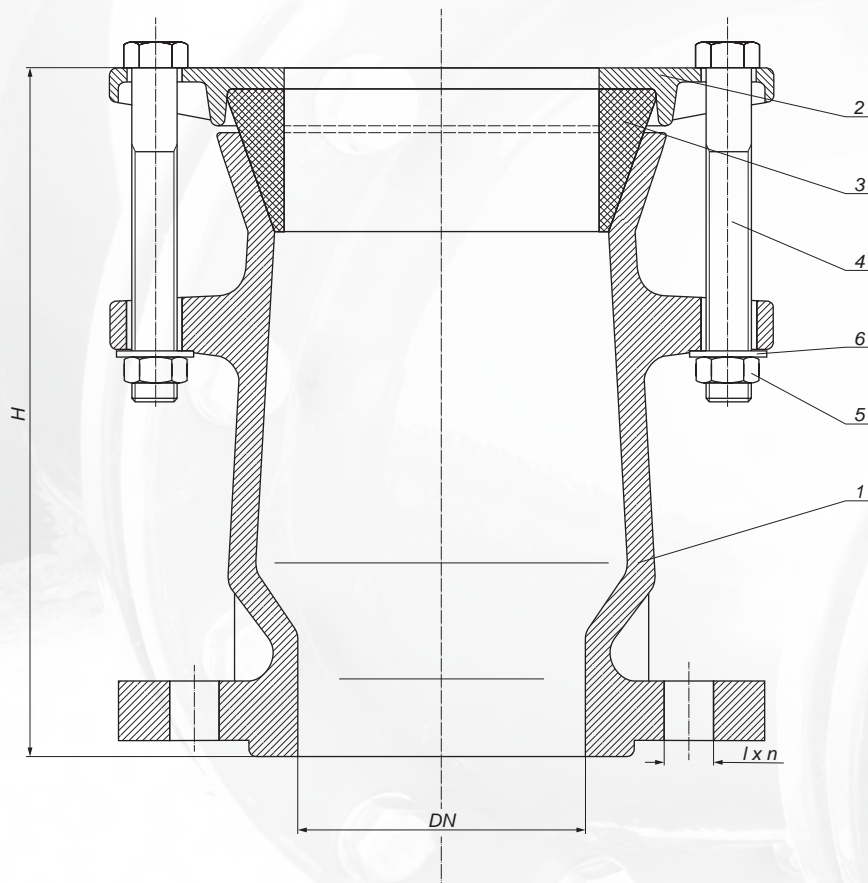

It is used to connect: cast iron, steel, AC and PE, PVC pipes with flanged fittings.

Coating: poliester paint min. 250 μm
Flange connection: PN-EN 1092-2:1999
Nominal pressure: 1,0/1,6 MPa; PN 10/16

No.	Description	Material
1.	Body	EN-GJS-500-7
2.	Ring	EN-GJS-500-7
3.	Gasket	EPDM/NBR
4.	Screw	Galvanized steel 8.8/ Stainless steel A2/A4
5.	Nut	
6.	Pad	

DN	DN/OD Range	H	l	n	Weight
80	88-102 mm	180	18	4(8)	9,30
80	88-103 mm	100	18	8	5,50
100	108-124 mm	190	18	8	11,60
100	107-128 mm	100	18	8	6,50
150	159-179 mm	200	22	8	17,50
150	159-182 mm	110	22	8	10,50
200	219-238 mm	215	22	8(12)	24,20
200	218-235 mm	170	22	8(12)	12,50
250	273-280 mm	120	22(26)	12	21,50
250	270-295 mm	190	22(26)	12	23,00
300	310-335 mm	140	22(26)	12	26,50
300	315-326 mm	208	22(26)	12	30,50