

Flanged gate valve type 002 F5 PN 10

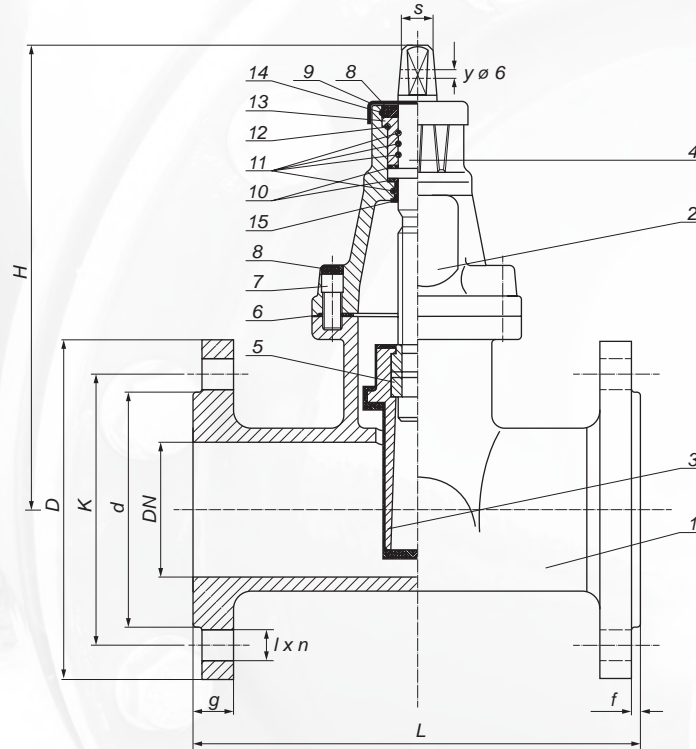

No.	Description	Pcs.	Material
1.	Body	1	EN-GJL-250
2.	Cover	1	EN-GJL-250
3.	Rubberized wedge	1	EN-GJL-250/EN-GJS-500-7/ EPDM/NBR
4.	Spindle	1	Stainless steel 2H13
5.	Nut	1	Brass MO59
6.	Cover gasket	1	EPDM/NBR
7.	Allen screw	4	Galvanized steel 8.8 class/Stainless steel A2
8.	Screw shield	5	Glue/paraffin
9.	Spindle shield	1	EPDM/NBR
10.	Bearing	2	Tarnamid
11.	Spindle O-ring	4	EPDM/NBR
12.	Choke O-ring	1	EPDM/NBR
13.	Choke	1	Brass MO59
14.	Protection ring	1	Special steel
15.	Locking sleeve	1	Tarnamid

It is used to cut off flow of chemically inert liquids of temperature up to 70°C in pipelines and installations.

Coating: poliester paint min. 250 µm

Overall lenght: PN-EN 558-1:2001 row 15

Flange connection: PN-EN 1092-2:1999

Nominal pressure: 1,0 MPa; PN 10

Requirements and inspection according to PN-EN 1074-1,2:2002

Option to exchange O-rings under pressure on a working pipeline.

DN	L	H	K	d	l	n	D	g	f	s	Weight
50	250	210	125	102	18	4	165	18	3	14	12,50
80	280	280	160	135	18	4(8)	200	20	3	17	20,00
100	300	290	180	155	18	8	220	20	3	19	23,50
150	350	400	240	212	22	8	285	20	3	19	40,50
200	400	500	295	266	22	8	340	25	3	24	80,50