

Coupling RR ductile iron PN 10/16

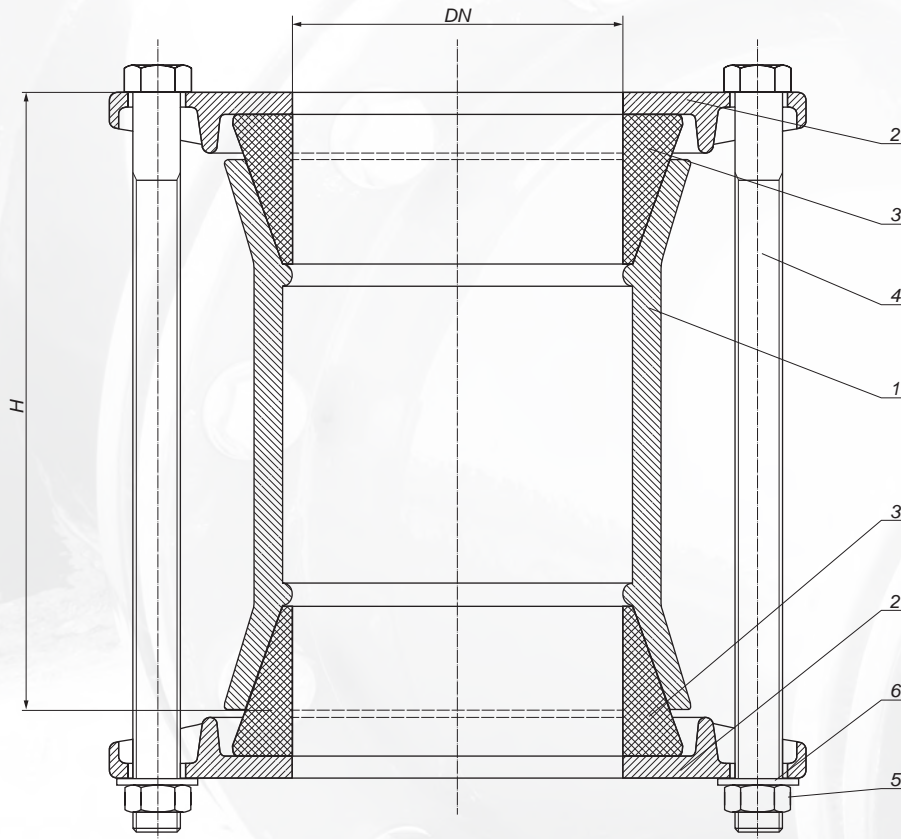

It is used to connect: cast iron, steel, AC and PE, PVC pipes
in various combinations.

Coating: poliester paint min. 250 μ m
Flange connection: PN-EN 1092-2:1999
Nominal pressure: 1,0/1,6 MPa; PN 10/16

No.	Description	Material
1.	Body	EN-GJS-500-7
2.	Ring	EN-GJS-500-7
3.	Gasket	EPDM/NBR
4.	Screw	Galvanized steel 8.8/ Stainless steel A2/A4
5.	Nut	
6.	Pad	

DN	DN/OD Range	H	Weight
80	88-102 mm	180	7,70
80	84-108 mm	175	5,50
100	108-124 mm	185	8,50
100	107-128 mm	175	6,60
150	159-179 mm	185	13,00
150	158-184 mm	210	10,00
200	219-238 mm	190	15,60
200	218-246 mm	210	13,50
250	270-295 mm	200	19,00
300	315-332 mm	200	21,50