

Telescope 290 with cover and grate

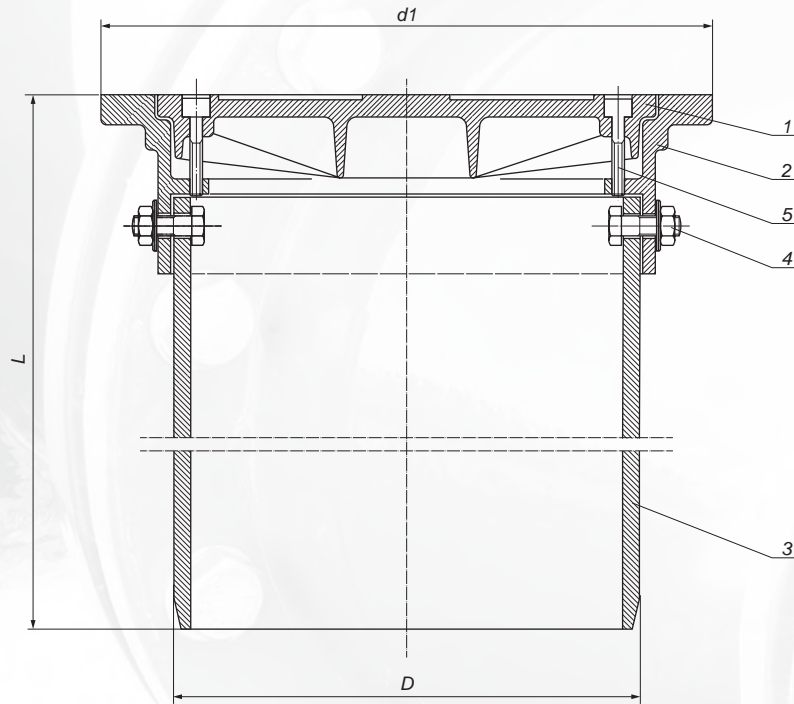

It is used as a top of inspection chamber size 315, 400 and 425.
The telescope is mounted on a rising pipe:
corrugated 315, smooth 400, corrugated 425
by the rubber adaptors:
MOW 290/315, MGW 290/400, MFW 290/425.

No.	Description	Material
1.	Lid*	EN-GJL-250
2.	Body	EN-GJL-250
3.	Pipe	PVC 290
4.	Screw, pad, nut	Galvanized steel 8.8 class/ Stainless steel A2
5.	Allen screw	Galvanized steel 8.8 class/ Stainless steel A2

Lid type	Load	Class	D	L	d1	Weight
Cover	1,5 T	A 15	290	500	355	16,00
	12,5 T	B 125	290	500	355	23,00
	25 T*	C 250	290	500	355	24,00
	40 T*	D 400	290	500	355	24,00
Grate	1,5 T	A 15	290	500	355	15,50
	12,5 T	B 125	290	500	355	22,50
	25 T*	C 250	290	500	355	23,50
	40 T*	D 400	290	500	355	23,50

Material: cast iron EN-GJL-250, PN-EN 1561:2012
* C 250, D 400 class - ductile iron EN-GJS-500-7, PN-EN 1563:2018.
No. 1., 2. bitumen paint.

Norm: PN-EN 124-2