

## Flanged cleaner TKH PN 10 and ductile iron PN 10/16

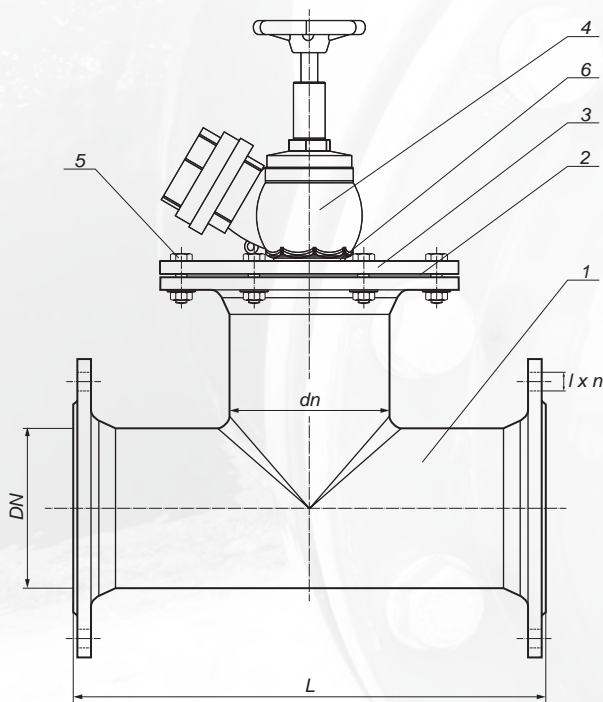

Flange cleaner with an inspection valve enables pipeline inspection, cleaning and flushing water supply and sewage network.

Coating: poliester paint UV resisted, min. 250 µm  
Flange connection: PN-EN 1092-2:1999  
Nominal pressure: 1,0/1,6 MPa, PN 10/16

No.	Description	Material
1.	Body	EN-GJL-250/EN-GJS-500-7
2.	Gasket	EPDM/NBR
3.	Flange	EN-GJL-250/EN-GJS-500-7
4.	Valve DN 50	AK11
5.	Screw, pad, nut	Galvanized steel 8.8 class/ Stainless steel A2/A4
6.	Gasket/O-ring	EPDM/NBR

DN	dn	L	l	n	Weight
50	50	300	18	4	11,50
65*	65	330	18	4	16,70
80	50	310	18	4(8)	20,40
	65*	330	18	4(8)	20,70
	80	330	18	4(8)	21,80
100	50	320	18	8	18,40
	65*	320	18	8	18,60
	80	360	18	8	19,00
	100	360	18	8	19,30
125*	80	400	18	8	23,10
	100	400	18	8	23,50
	120	400	18	8	23,90
150	50*	440	22	8	29,00
	65*	440	22	8	30,00
	80	440	22	8	30,50
	100	440	22	8	32,50
	125*	440	22	8	33,00
200	150	440	22	8	34,00
	80	520	22	8(12)	45,00
	100	520	22	8(12)	46,00
	150	520	22	8(12)	48,00
250*	200	520	22	8(12)	49,00
	80	700	22(26)	12	65,00
	100	700	22(26)	12	69,00
	150	700	22(26)	12	70,00
	200	700	22(26)	12	80,00
300*	250	700	22(26)	12	89,00
	80	800	22(26)	12	93,00
	100	800	22(26)	12	97,00
	150	800	22(26)	12	98,00
	200	800	22(26)	12	105,00
	250	800	22(26)	12	116,00
	300	800	22(26)	12	125,00

\* Products available only in ductile iron version EN-GJS-500-7