

Telescope 250 with cover and grate

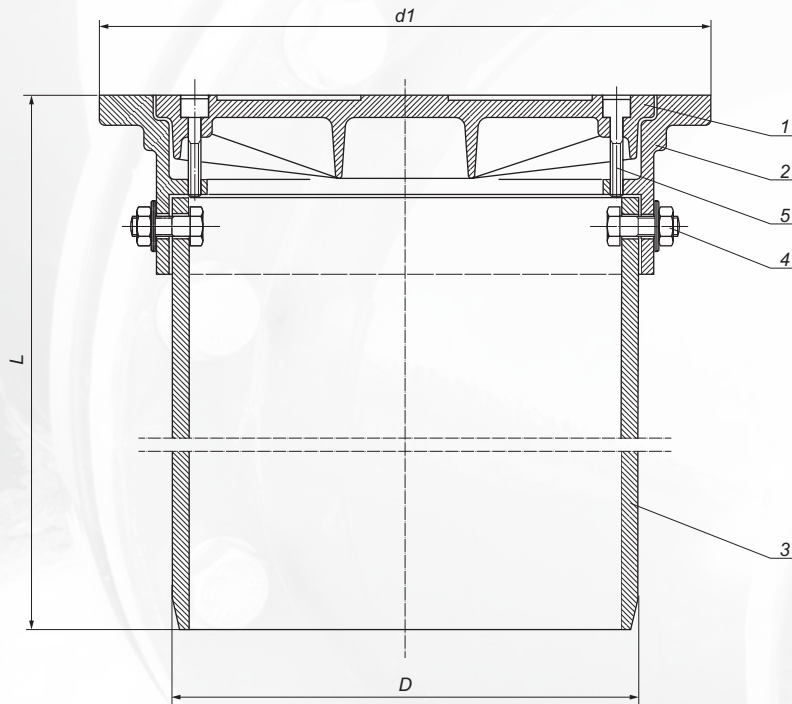

It is used as a top of inspection chamber size 250/315.
Based on a smooth pipe Dn 250 and connected to the rising
smooth pipe Dn 315 by the TW 250/315 rubber adaptor.

No.	Description	Material
1.	Lid*	EN-GJL-250
2.	Body	EN-GJL-250
3.	Pipe	PVC 250
4.	Screw, pad, nut	Galvanized steel 8.8 class
5.	Allen screw	Galvanized steel 8.8 class/ Stainless steel A2

* D 400 class - ductile iron EN-GJS-500-7, PN-EN 1563:2000.
No. 1., 2. bitumen paint.

Lid type	Load	Class	D	L	d1	Weight
Cover	1,5 T	A 15	250	550	320	12,80
	12,5 T	B 125	250	550	320	15,20
	40 T	D 400	250	550	320	16,10
Grate	1,5 T	A 15	250	550	320	12,60
	12,5 T	B 125	250	550	320	15,00
	40 T	D 400	250	550	320	16,00

Norm: PN-EN 124-2