

Spotting drill NS (self-drilling) for PE and PVC pipes PN 10 and ductile iron PN 10/16

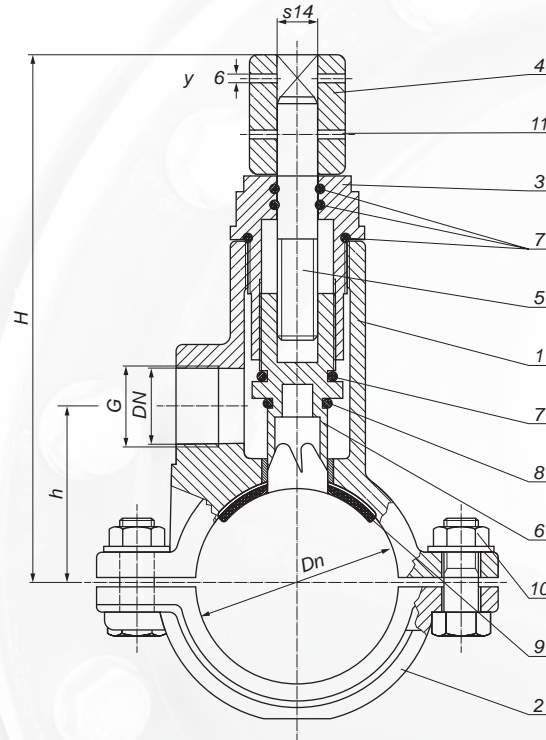

It is used for connecting home installations to the water supply pipeline made of PE and PVC pipes without the use of additional equipment. The connection can be made on the working water supply network.

Medium: non-aggressive liquids with a temperature up to 70°C
Coating: poliester paint min. 250 µm
Nominal pressure: 1,0/1,6 MPa; PN 10/16

| No. | Description | Pcs. | Material |
|-----|---------------------|------|--|
| 1. | Body | 1 | EN-GJL-250/EN-GJS-500-7 |
| 2. | Saddle | 1 | EN-GJL-250/EN-GJS-500-7 |
| 3. | Plug screw | 1 | EN-GJL-250/EN-GJS-500-7 |
| 4. | Cap | 1 | EN-GJL-250/EN-GJS-500-7 |
| 5. | Spindle | 1 | Stainless steel 2H13 |
| 6. | Rotary knife | 1 | Stainless steel 2H13 |
| 7. | O-ring | 4 | EPDM/NBR |
| 8. | Set gasket | 1 | EPDM/NBR |
| 9.* | Upper saddle gasket | 1 | EPDM/NBR |
| 10. | Screw, pad, nut | 2 | Galvanized steel 8.8 class/ Stainless steel A2/A4 |
| 11. | Rivet | 1 | Steel |

* It is possible to make a clamp with full rubber lining.

| Dn | G | DN | H | h | Weight |
|-----|------|-----|------|-----|--------|
| 63 | 5/4" | 32 | 220 | 60 | 4,70 |
| 90 | | | 230 | 75 | 5,80 |
| 110 | | | 240 | 85 | 6,50 |
| 125 | | | 310 | 135 | 8,20 |
| 160 | | | 260 | 115 | 7,50 |
| 225 | 355 | 185 | 9,70 | | |
| 63 | 6/4" | 40 | 220 | 60 | 4,60 |
| 90 | | | 230 | 75 | 5,70 |
| 110 | | | 240 | 85 | 6,40 |
| 125 | | | 310 | 135 | 8,10 |
| 160 | | | 260 | 115 | 7,40 |
| 225 | 355 | 185 | 9,60 | | |
| 90 | 2" | 50 | 290 | 115 | 6,60 |
| 110 | | | 300 | 125 | 7,60 |
| 125 | | | 310 | 135 | 8,00 |
| 160 | | | 325 | 155 | 8,50 |
| 225 | | | 355 | 185 | 9,50 |