

Telescope 425 with cover and grate

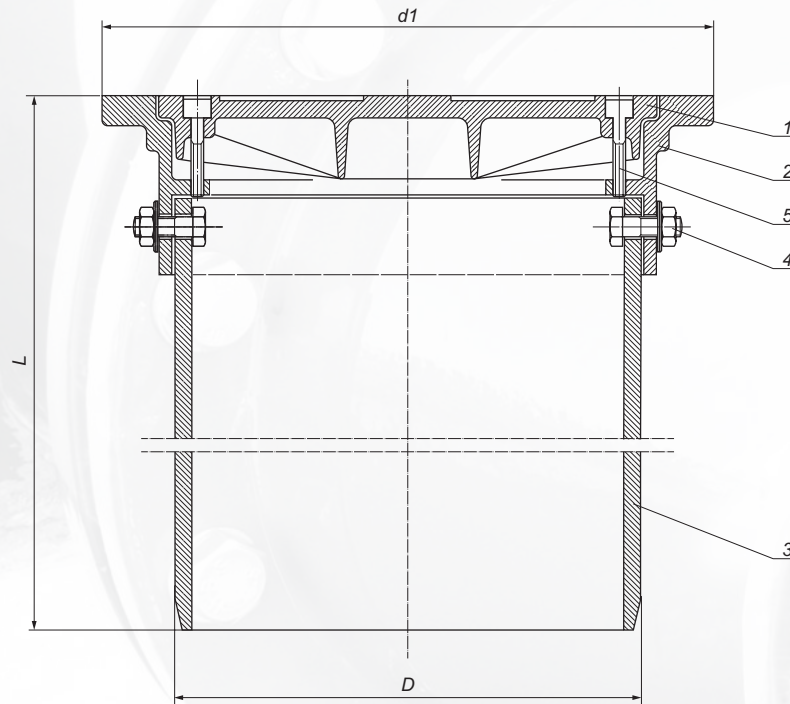

It is used as a top of inspection chamber size 425.
The telescope is mounted on a 425 corrugated rising pipe,
by the rubber adaptors:
KW 400/425, KWN 400/425 and WW 400/425.

No.	Description	Material
1.	Lid*	EN-GJL-250
2.	Body	EN-GJL-250
3.	Pipe	PVC 396
4.	Screw, pad, nut	Galvanized steel 8.8 class
5.	Allen screw	Galvanized steel 8.8 class/ Stainless steel A2

* C 250, D 400 class - ductile iron EN-GJS-500-7, PN-EN 1563:2000.
No. 1., 2. bitumen paint.

Lid type	Load	Class	D	L	d1	Weight
Cover	1,5 T	A 15	396	550	500	30,00
	12,5 T	B 125	396	550	500	38,00
	25 T	C 250	396	550	500	40,00
	40 T	D 400	396	550	500	40,00
Grate	1,5 T	A 15	396	550	500	29,50
	12,5 T	B 125	396	550	500	37,50
	25 T	C 250	396	550	500	39,50
	40 T	D 400	396	550	500	39,50

Norm: PN-EN 124-2