

Flanged bend ŁŁK 45° ductile iron PN 10/16

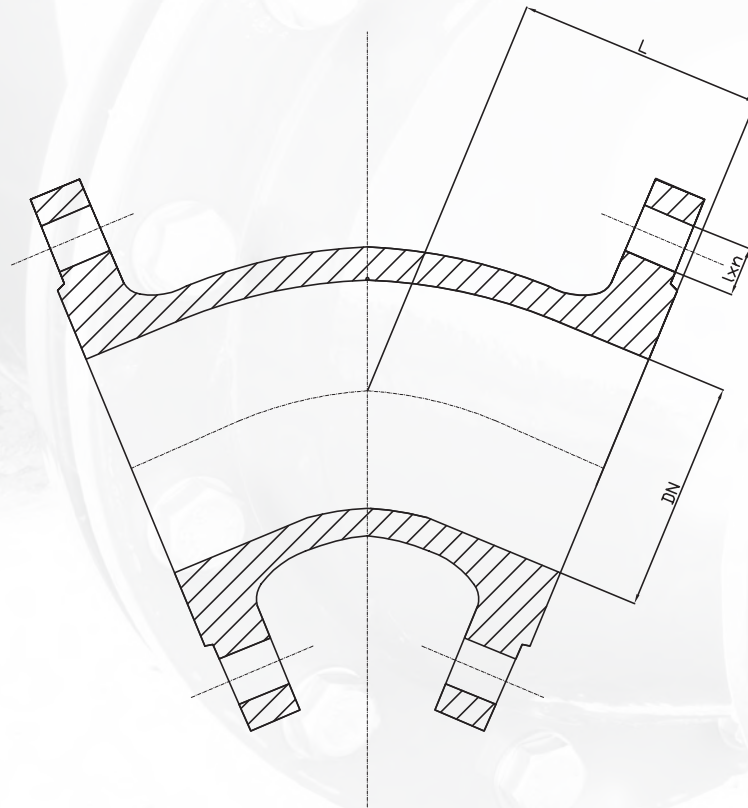

It is used to turn the course of supply systems.

Coating: poliester paint min. 250 μm
 Material: ductile iron, EN-GJS-500-7, PN-EN 1563:2018
 Flange connection: PN-EN 1092-2:1999
 Nominal pressure: 1,0/1,6 MPa; PN 10/16

DN	L	l	n	Weight
80	130	18	8	9,70
100	140	18	8	11,90
150	160	22	8	21,00
200	180	22	8(12)	33,60